

Submersible DRAINAGE pumps

Помпа потопяема дренажна за чиста или леко замърсена вода
TOP 3 10MT

 Clear water

 Domestic use



PERFORMANCE RANGE

- Flow rate up to **360 l/min** (21.6 m³/h)
- Head up to **15.5 m**

APPLICATION LIMITS

- Immersion depth:
 - up to **3 m** for TOP 1-2-3
 - up to **5 m** for TOP 4-5 (with a sufficiently long power cable)
- Maximum liquid temperature **+40 °C** (Maximum liquid temperature +90 °C for a maximum of 3 minutes intermittent service)
- Passage of suspended solids up to **Ø 10 mm**
- Suction level:
 - **14 mm** above ground level for TOP 1-2-3
 - **30 mm** above ground level for TOP 4-5
- Continuous service **S1**

CONSTRUCTION AND SAFETY STANDARDS

The pumps are complete with:

- **5 m** long power cable for TOP 1-2-3
- **10 m** long power cable for TOP 4-5
- float switch

EN 60335-1
IEC 60335-1
CEI 61-150

EN 60034-1
IEC 60034-1
CEI 2-3



INSTALLATION AND USE

The **TOP** series is suitable for use with **clear water** that does not contain abrasive particles.

Because of the design solutions that have been adopted, such as the complete cooling of the motor and the shaft with double seal, these pumps are easy to use and reliable.

They are suitable for use in applications such as draining small flooded areas (rooms, cellars, garages) in the event of an emergency, for the disposal of waste water in the home (from dishwashers, washing machines) and for emptying drainage traps.

PATENTS - TRADE MARKS - MODELS

- Registered EU Design n. 342159-0011

OPTIONS AVAILABLE ON REQUEST

- **"TOP-GM"** pumps with vertical float switch (suitable for particularly small wells)
- **"TOP 2-3 LA"** pumps intended for use with aggressive liquids
- Special mechanical seal
- TOP 1-2-3 pumps with **10 m** long power cable
 - ➔ N.B. Standard EN 60335-2-41 states that the power cable must be 10 m long for outdoor applications
- Pumps without float switch
- Other voltages or 60 Hz frequency

CERTIFICATIONS

Company with management system certified DNV
ISO 9001: QUALITY
ISO 14001: ENVIRONMENT



CHARACTERISTIC CURVES AND PERFORMANCE DATA

50 Hz n= 2900 rpm

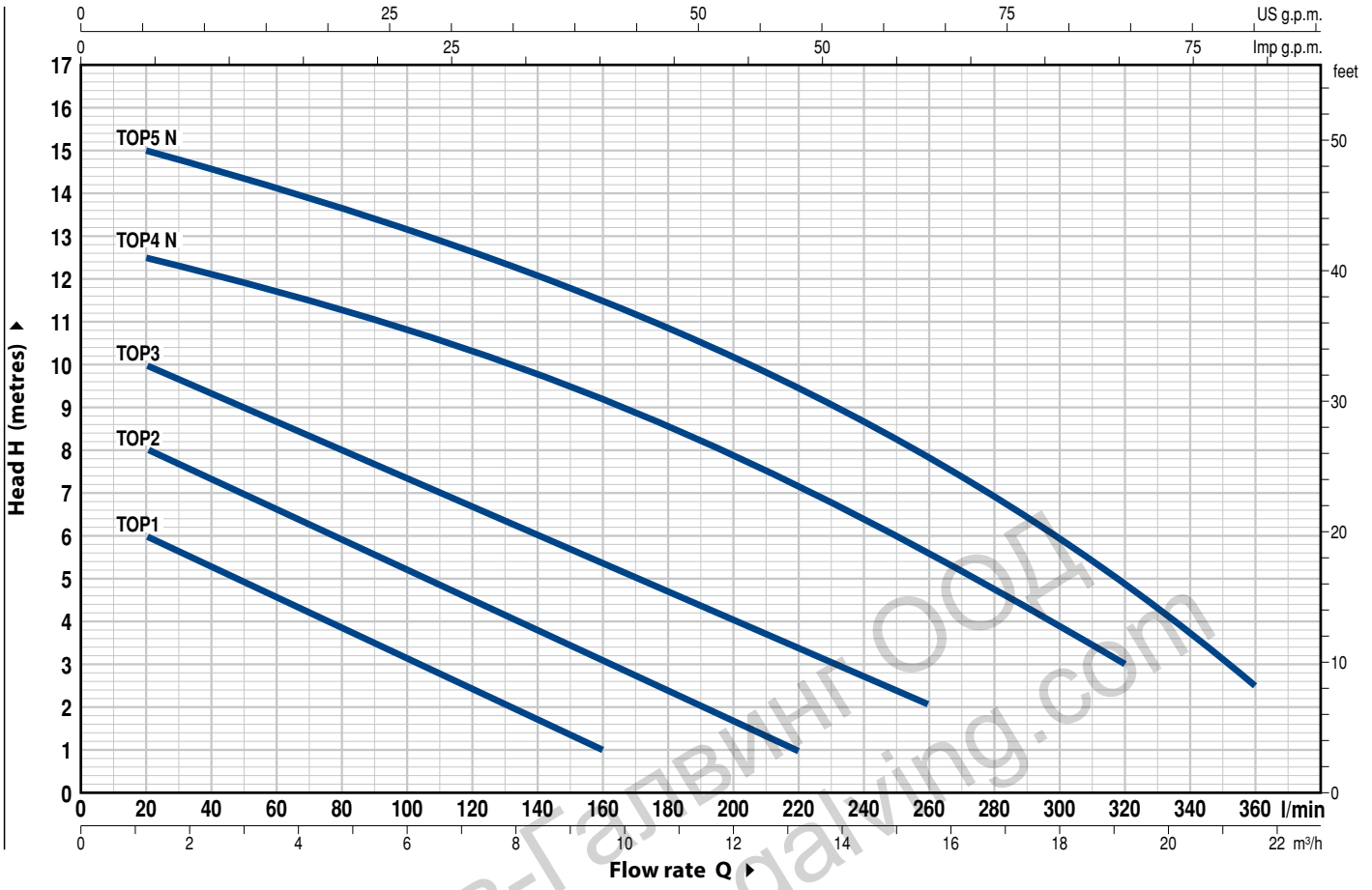

MODEL	POWER (P ₂)		Q	Flow rate																				
	kW	HP		0	1.2	2.4	3.6	4.8	6.0	7.2	8.4	9.6	10.8	12	13.2	14.4	15.6	16.8	18.0	19.2	20.4	21.6		
Single-phase			l/min	0	20	40	60	80	100	120	140	160	180	200	220	240	260	280	300	320	340	360		
TOP 1	0.25	0.33	H metres	7	6	5.5	4.5	4	3	2.5	1.5	1												
TOP 2	0.37	0.50		9	8	7.5	6.5	6	5.5	4.5	4	3	2.5	1.8	1									
TOP 3	0.55	0.75		10.5	10	9	8.8	8	7.5	6.5	6	5.5	4.8	4	3.5	2.5	2							
TOP 4 N	0.75	1		13	12.5	12.1	11.6	11.3	10.8	10.3	9.8	9.2	8.5	7.9	7.1	6.4	5.5	4.7	3.9	3				
TOP 5 N	0.92	1.25		15.5	15	14.5	14.1	13.6	13.2	12.6	12	11.5	10.8	10	9.4	8.5	7.8	6.8	6	4.8	3.6	2.5		

Q = Flow rate H = Total manometric head

Tolerance of characteristic curves in compliance with EN ISO 9906 Grade 3B.

POS. COMPONENT CONSTRUCTION CHARACTERISTICS

1	PUMP BODY	Technopolymer
2	SUCTION FILTER	Technopolymer
3	SUCTION PLATE	Stainless steel AISI 304 (AISI 316L for LA versions)
4	DIFFUSER	Technopolymer
5	IMPELLER	Noryl FE1520PW
6	MOTOR CASING	Stainless steel AISI 304 (AISI 316L for LA versions)
7	MOTOR CASING PLATE	Stainless steel AISI 304
8	MOTOR SHAFT	Stainless steel EN 10088-3 - 1.4104 (AISI 316L for LA versions)

9 SHAFT WITH DOUBLE SEAL AND OIL CHAMBER

Pump Model	Seal Model	Shaft Diameter	Materials			
			Stationary ring	Rotational ring	Elastomer	Metals
TOP 1-2-3 TOP 1-2-3 GM	STA-12R	Ø 12 mm	Ceramic	Graphite	NBR	AISI 304
TOP 2-3 LA	AR-12R LA	Ø 12 mm	Ceramic	Graphite	NBR	AISI 316

10 **LIP SEAL** Ø 12 x Ø 19 x H 5 mm

11 **BEARINGS** 6201 ZZ / 6201 ZZ

12 CAPACITOR

Pump Single-phase	Capacitance	
	(230 V or 240 V)	(110 V)
TOP 1	10 µF 450 VL	16 µF - 250 VL
TOP 2	10 µF 450 VL	16 µF - 250 VL
TOP 3	14 µF 450 VL	16 µF - 250 VL

13 ELECTRIC MOTOR

TOP: single-phase 230 V - 50 Hz with thermal overload protector incorporated into the winding.
 – Insulation: class F
 – Protection: IP X8

14 HANDLE ASSEMBLY (resin sealed)

Complete with:
 – 5 metres long “H07 RN-F” power cable with Schuko plug
 – Float switch
 (Vertical float switch in the GM versions)

15 HOSE CONNECTOR WITH RING NUT

Ø 25 mm hose connection for TOP 1
 Ø 35 mm for TOP 2-3

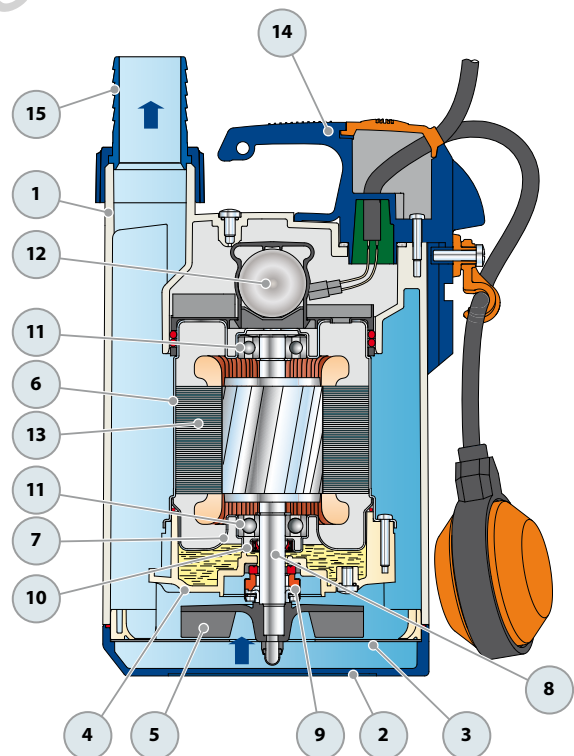

DIMENSIONS AND WEIGHT

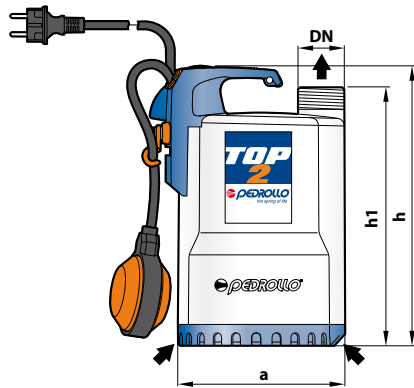

Standard installation

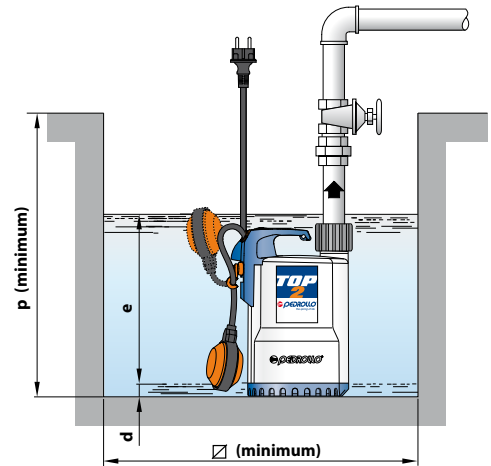

MODEL	PORT	DIMENSIONS mm							kg	
		a	h	h1	d	e	p	Ø		
Single-phase	DN									
TOP 1	1 1/4"	152	257	237	14	variable	350	350		5.2
TOP 2			287	267						5.2
TOP 3										6.6

Version with vertical float switch

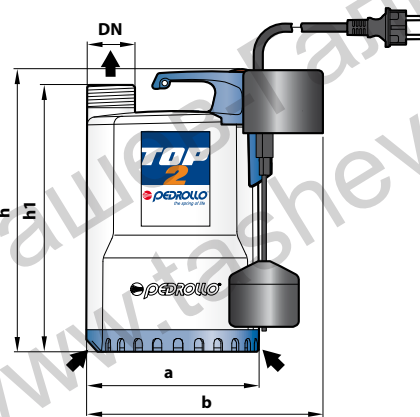

Standard installation

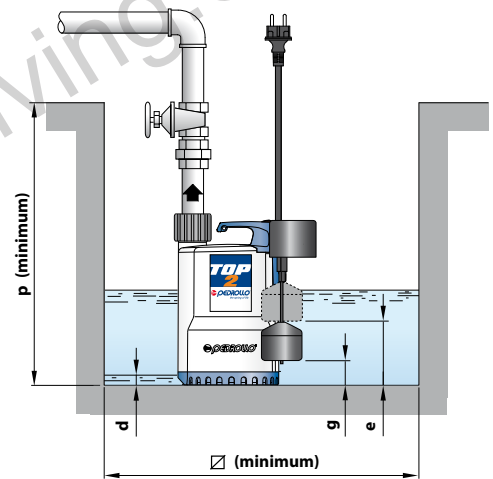

MODEL	PORT	DIMENSIONS mm									kg
		a	b	h	h1	d	e	g	p	Ø	
Single-phase	DN										
TOP 1-GM	1 1/4"	152	200	257	237	14	140	35	350	220	5.3
TOP 2-GM				287	267		170	40			5.3
TOP 3-GM							6.7				

ABSORPTION

MODEL	VOLTAGE		
	230 V	240 V	110 V
Single-phase			
TOP 1	1.5 A	1.4 A	3.0 A
TOP 2	2.0 A	1.9 A	5.3 A
TOP 3	3.2 A	3.1 A	7.9 A

PALLETIZATION

MODEL	GROUPAGE	CONTAINER
Single-phase	n. pumps	n. pumps
TOP 1	96	144
TOP 2	96	144
TOP 3	96	144

POS. COMPONENT CONSTRUCTION CHARACTERISTICS

1	PUMP BODY	Technopolymer
2	SUCTION FILTER	Technopolymer
3	SUCTION PLATE	Stainless steel AISI 304
4	DIFFUSER	Technopolymer
5	IMPELLER	Noryl FE1520PW
6	MOTOR CASING	Stainless steel AISI 304
7	MOTOR CASING PLATE	Stainless steel AISI 304
8	MOTOR SHAFT	Stainless steel EN 10088-3 - 1.4104

9 SHAFT WITH DOUBLE MECHANICAL SEAL SEPARATED BY AN OIL CHAMBER

Seal Model	Shaft Diameter	Position	Materials		
			Stationary ring	Rotational ring	Elastomer
MG1-14D SIC	Ø 14 mm	Motor side	Silicon carbide	Graphite	NBR
		Pump side	Silicon carbide	Silicon carbide	NBR

10 BEARINGS 6203 ZZ / 6203 ZZ

11 CAPACITOR

Pump Single-phase	Capacitance (230 V or 240 V)	(110 V)
TOP 4 N	16 µF 450 VL	30 µF - 250 VL
TOP 5 N	20 µF 450 VL	30 µF - 250 VL

12 ELECTRIC MOTOR

TOP: single-phase 230 V - 50 Hz with thermal overload protector incorporated into the winding.
 – Insulation: class F
 – Protection: IP X8

13 HANDLE ASSEMBLY (resin sealed)

Complete with:
 – **10 metres** long "H07 RN-F" power cable with Schuko plug
 – Float switch
 (Vertical float switch in the GM versions)

14 HOSE CONNECTOR WITH RING NUT

Hose connection Ø 41 mm

15 PIPE COUPLING

In technopolymer with 1½" thread and non-return valve

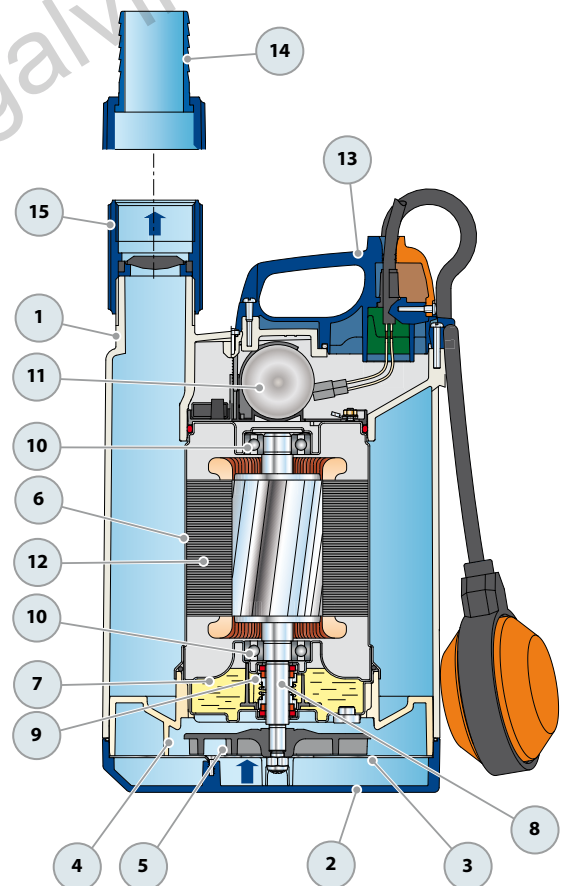

DIMENSIONS AND WEIGHT

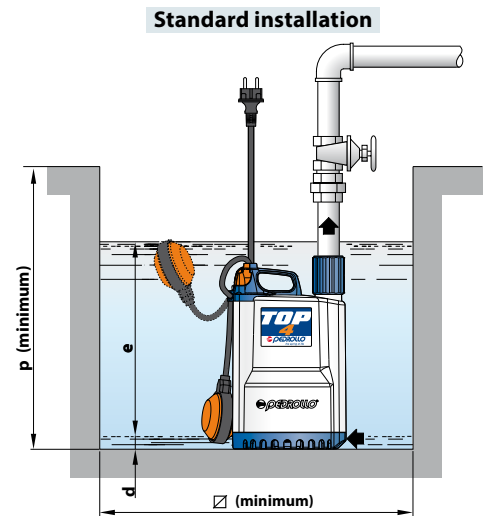
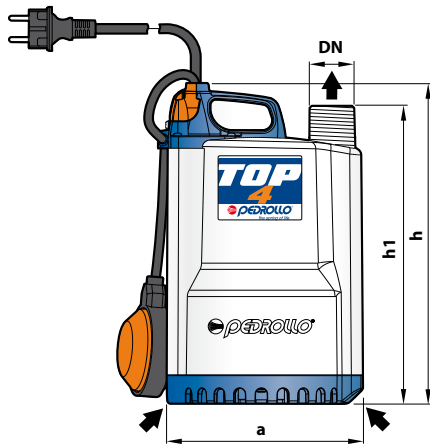

MODEL	PORT	DIMENSIONS mm								kg
		DN	a	h	h1	d	e	p	∅	
Single-phase	DN									
TOP 4 N	1½"	204	337	313	30	variable	450	450		10.2
TOP 5 N										11.1

Version with vertical float switch

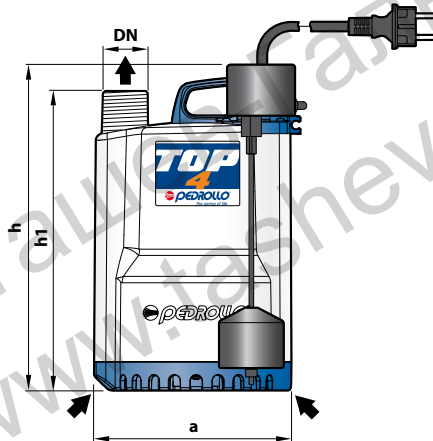

Standard installation

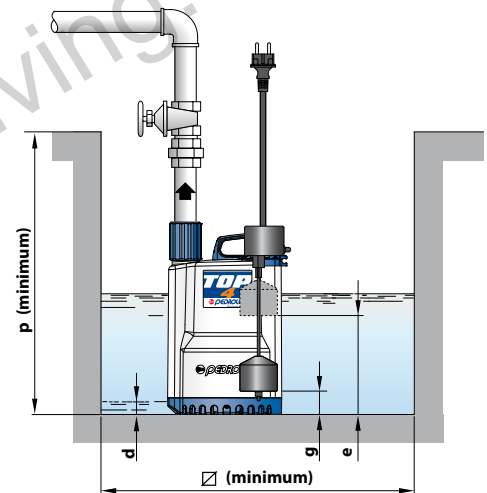

MODEL	PORT	DIMENSIONS mm								kg
		DN	a	h	h1	d	e	g	p	
Single-phase	DN									
TOP 4 N - GM	1½"	204	337	313	30	220	65	450	300	10.3
TOP 5 N - GM										11.2

ABSORPTION

MODEL	VOLTAGE		
	230 V	240 V	110 V
Single-phase			
TOP 4 N	4.5 A	4.4 A	9.0 A
TOP 5 N	5.5 A	5.4 A	11.0 A

PALLETIZATION

MODEL	GROUPAGE	CONTAINER
Single-phase		
TOP 4 N	60	100
TOP 5 N	60	100